

T1110 TRANSMITTER

**Programmable relative humidity transmitter
with 4-20 mA output**

Instruction Manual

Instruction manual for use of T1110 transmitter

Transmitter is designed for measurement of ambient relative humidity of non-aggressive air. Measuring temperature and relative humidity sensors are non-removable instrument parts. Measured values are displayed on dual line LCD display, where reading displayed on the second LCD line is relative humidity. It is possible to switch OFF the LCD at all. Transmitter is connected to circuitry by means of one current loop. Please read instruction manual before the first device connection.

All transmitter setting is performed by means of the PC connected via the optional SP003 communication cable (not included in delivery). Program *Tsensor* for transmitter setting is available to download free at www.cometsystem.cz. Program enables to set the output range of relative humidity. It supports make the adjustment of the device too. This procedure is described at file „*Calibration manual.pdf*“ which is installed commonly with the software.

Device setting from the manufacturer

Transmitter is set from the manufacturer to the following parameters:

value at output I1: relative humidity, range 4 – 20 mA corresponds 0 to 100 % RH

display: switched ON

value displayed at line 2: relative humidity

Modification of the setting is possible to do by means of the PC using procedure described at the end of this document.

Installation of the transmitter

Transmitter is designed for wall mounting. There are two mounting holes at the sides of the case. It is NOT recommended to use the device for long time under condensation conditions. It could be the cause of water steam condensation inside the sensor's cover into water phase. This liquid phase stays inside sensor's cover and can't escape from the cover easily. It can dramatically increase response time to relative humidity change. If water condensation occurs for longer time it can cause sensor damage. Similar effect can occur under water aerosol conditions. Don't connect transmitter while power supply voltage is on. Interconnection terminals are accessible after unscrewing four screws and removing the lid. Lace the cable through a gland at the case wall. Connect the cable to terminals with respecting the signal polarity (see figure). Terminals are self-clamping and can be opened by a suitable screwdriver. For the opening, insert the screwdriver to upper terminal hole and lever by him. Do not remember to tighten glands and case lid with inserted packing after cables connecting. It is necessary for warranting of protection IP65.

It is recommended to use shielded copper cable (e.g. SYKFY) with outside diameter of the cable must be from 3.5 to 8 mm, maximal length 1200m. The cable must be located at indoor rooms (probe is not protected for outdoor use). The cable should not be led in parallel along power cabling. Safety distance is up to 0.5 m otherwise undesirable induction of interference signals can appear.

Electrical system (wiring) may do only worker with required qualification by rules in operation.

Dimensions

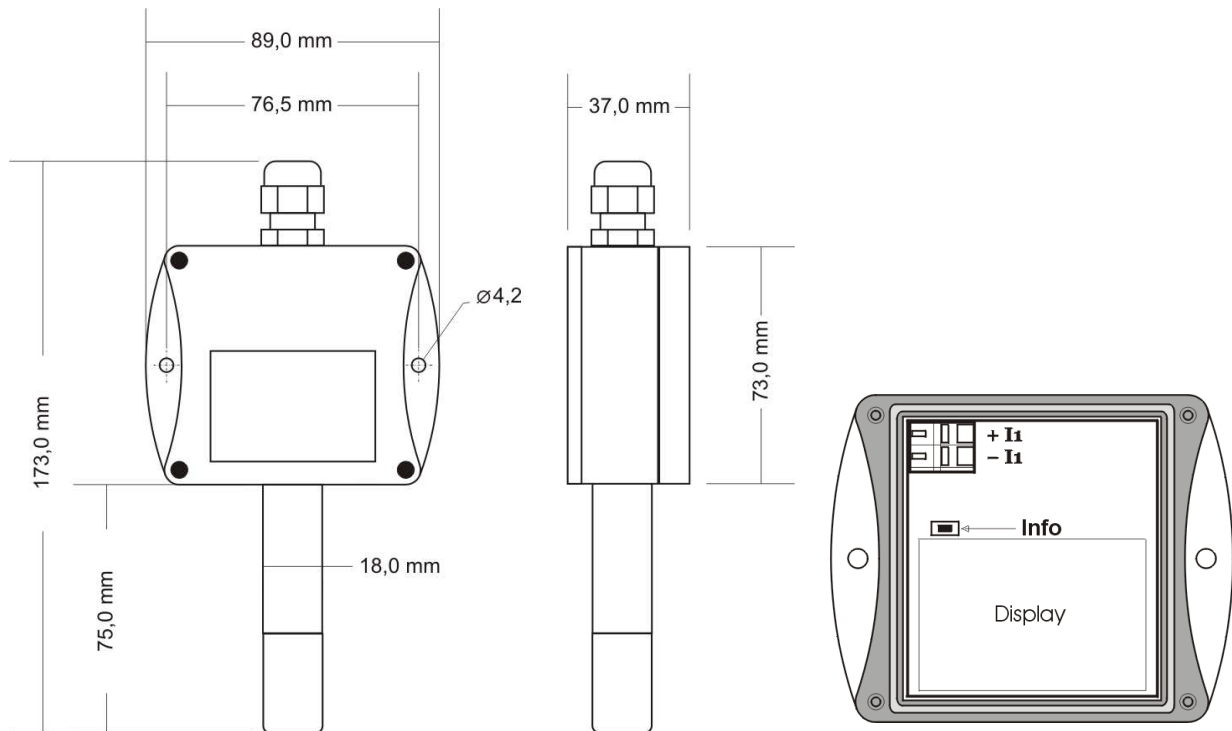

Typical application wiring

Calculation of minimum power voltage U_{ss} for proper operation:

$$U_{ss \min} > U_0 \min + I_{\max} * R_z,$$

where: $U_0 \min = 9 \text{ V}$

I_{\max} ... approximately 20 mA

R_z ... sensing resistor (shunt)

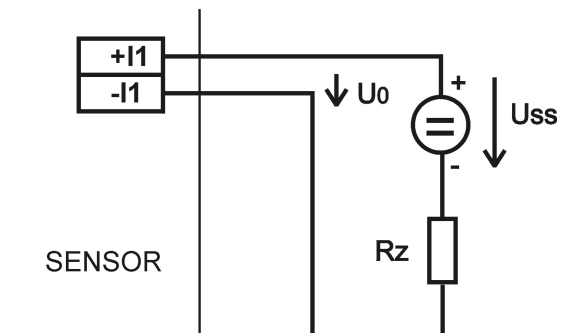

LCD Info mode

Several settings of installed transmitter is possible to verify without a use of the computer. It is necessary to connect at least power of current loop I_1 .

Unscrew the transmitter lid and shortly press button between display and interconnection terminals by means of a tool (e.g. screwdriver).

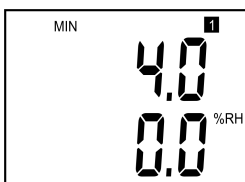

Range and type of value for output 1 (current loop I_1 = symbol „1“ on display). Type of value, assigned to output 1, is indicated by displayed unit (here %RH = relative humidity). Upper line displays current value corresponding to measured value (lower line). Here 4 mA corresponds to 0 %RH

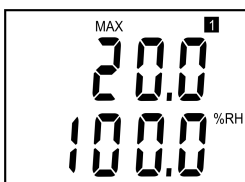

Press button again to get value for upper point (same output, same value) similarly as at previous point. Here 20 mA corresponds to 100 %RH.

Press button again to end info mode and display actual measured values.

Notice: during info mode no measurement and no output current generation proceed. The transmitter stays at info mode 15 s, then automatically goes back to measuring cycle.

Readings on LCD display

%RH

Reading next to this symbol is measured relative humidity or error state of value.

Technical parameters:

Analog output (for relative humidity output only):

Output range: from 4 to 20 mA

Current output in case of error: <3.8 mA or >24 mA

Power: 9 to 30 V dc, maximum ripple 0.5 %

Measuring parameters:

Ambient temperature (internal RTD sensor Pt1000/3850ppm):

Measuring range: -30 to +80 °C

Display resolution: 0.1 °C

Accuracy: ± 0.4 °C

Relative humidity (RH reading is compensated at the entire temperature range):

Measuring range: 0 to 100 %RH (see Installation of the transmitter)

Display resolution: 0.1 %RH

Accuracy: ± 2.5 %RH from 5 to 95 %RH at 23 °C (for value on LCD display and for values on analog output too)

Response time with stainless steel mesh sensor cover (F5200) and bronze sensor cover (F0000, selectable option), air flow approximately 1 m/s:

relative humidity: $t_{90} < 50$ s (humidity step 30 %RH, constant temperature)

Recommended interval of calibration: 1 year

Measuring interval and LCD display refresh: 0.5 s

Communication with computer: via USB port by means of USB communication cable SP003

Protection: electronics IP65, sensors are located in cover with IP40 protection

Air filter: filtering ability 0.025 mm

Operating conditions:

Operating temperature range: -30 to +80 °C, over +70°C switch LCD display OFF

Operating humidity range: 0 to 100 %RH

Outer characteristics in accordance with EN 33-2000-3:

normal environment with the specifications: AE1, AN1, BE1

Working position: the stem downwards

Electromagnetic compatibility: complies EN 61326-1

Not allowed manipulations:

It is not allowed to operate the device under other than specified conditions in technical parameters. Devices are not designed for locations with chemically aggressive environment. Temperature and humidity sensors must not be exposed to direct contact to water or other liquids. It is not allowed to remove the sensor cover to avoid any mechanical damage of the sensors.

Storing conditions: temperature -30 to +80 °C, humidity 0 to 100 %RH without condensation

Dimensions: 89 x 73 x 37 mm, stem length 75 mm

Weight: approximately 115 g

Material of the case: ABS

Procedure of modification of transmitter adjustment:

- device adjustment is performed by means of the optional SP003 communication cable, connected to USB port of the PC.
- It is necessary to have installed configuration program Tsensor on the PC, It is free to download at www.cometsystem.cz. During installation please take care about installation of driver for USB communication cable
- Connect SP003 communication cable to the PC. Installed USB driver detect connected cable and create virtual COM port inside the PC.
- Unscrew four screws of the device lid a remove the lid. If device is already installed to measuring system, disconnect leads from terminals
- Connect SP003 communication cable to the device. Display must light up, or at least must light up all symbols for one second (if LCD was switched OFF by program before).
- Run installed Tsensor program and select corresponding communication COM port (as described above).
- When new setting is saved and finished, disconnect the cable from the device, connect leads into its terminals and place the lid back to the device.

Error States of the device

Device continuously checks its state during operation. In case error is found LCD displays corresponding error code:

Error 0

First line displays „Err0“.

Check sum error of stored setting inside device's memory. Output value is < 3.8 mA. This error appears if incorrect writing procedure to device's memory occurred or if damage of calibration data appeared. At this state device does not measure and calculate values. It is the serious error, contact distributor of the instrument to fix.

Error 1

Measured value is over upper limit of allowed full scale range. There is a reading „Err1“ on LCD display. Output value is about 24.5 mA. This state appears in case of:

- Measured temperature is higher than approximately 600°C (i.e. high non-measurable resistance of temperature sensor, probably opened circuit).
- Relative humidity is higher than 100%, i.e. damaged humidity sensor, or humidity calculation of humidity is not possible (due to error during temperature measurement)

Error 2

There is a reading „Err2“ on LCD display. Output value is about 3.8 mA. Measured value is below lower limit of allowed full scale range. This state appears in case of:

- Measured temperature is lower than approximately -210°C (i.e. low resistance of temperature sensor, probably short circuit).
- Relative humidity is lower than 0%, i.e. damaged sensor for measurement of relative humidity, or calculation of humidity is not possible (due to error during temperature measurement)

Error 3

There is a reading „Err3“ on LCD display upper line.

Error of internal A/D converter appeared (converter do not respond, probably damage of A/D converter). No measurement and calculations of values proceed. Output value is about 3.8 mA. It is a serious error, contact distributor of the instrument.

End of operation

Device itself (after its life) is necessary to liquidate ecologically!

Technical support and service

Technical support and service is provided by distributor. For contact see warranty certificate.

Notes:
