

*REGULATORS OF AIR RELATIVE HUMIDITY
HGSD, HGS-150D, HGS-700D
(HUMIDISTATS)*

Instruction Manual

Regulators of relative humidity are designed for two-state control of e.g. heating, ventilation, humidifiers, dehumidifiers etc. in non-aggressive environment. When adjusted humidity level is reached, relay contact for connected device control is switched over and signal LED is switched ON. It is possible to adjust the humidity level for control by means of a selector on the front of the plastic case. The step of adjustment is 1%RH. DIP switch inside also enables to adjust hysteresis to $\pm 1\%$ RH from the control level or $\pm 2\%$ RH from the control level. Regulators are available in wall-mount, duct-mount and bar types. Regulator contains microprocessor based control circuitry in a durable watertight plastic case with connection terminals and humidity sensor in a bronze sintered filter. Computerized design ensures maximum long term stability and temperature compensation of the humidity sensor.

State-of-the-art capacitive polymer sensor ensures excellent calibration long term stability, inertia against water and condensation.

Technical parameters:

Range of regulated relative humidity:	0 to 100 %RH
Adjustment step for setting of limit humidity value:	1 %RH
Accuracy:	$\pm 2,5$ %RH from 5 to 95 %RH at 23°C
Hysteresis (selectable by jumper):	1. zone ± 1 %RH from adjusted limit value 2. zone ± 2 %RH from adjusted limit value
Response time:	$t_{63} < 20$ s, $t_{90} < 30$ s (humidity step from 11 to 75 %RH and airflow 0,5 m/s)
Operational temperature range of electronics:	-30 to +80 °C
Operational temperature range of RH sensor:	-30 to +105 °C with the limitation in graph below (only for regulators HGS-150D and HGS-700D)
Power:	230V-50Hz, consumption max. 0,35VA, internal fuse T63mA
Parameters of output relay:	maximum switching current: 6 A maximum switching voltage: 250 V ac, 125 V dc
Protection:	IP2x
Filtering ability of bronze cover:	0,025 mm
Outer influence accordingly to EN 33-2000-3:	normal environment with characteristics AE1, AM1, BA4, BE3, CB1
Not allowed manipulations:	It is not allowed to operate the device under other than specified conditions in technical parameters. Device is not designed for locations where mechanical vibrations can appear and for locations with chemically aggressive environment. It is not allowed to operate or store the transmitter without sintered bronze cover.
Storing conditions:	-30 to +85 °C at 0 to 100 %RH humidity (no condensation)
Case dimensions without glands:	115 x 65 x 40 mm
Stalk lengths:	67 mm (HGSD) 150 mm (HGS-150D) 700 mm (HGS-700D)
Weight:	approximately 250 g (HGSD) approximately 350 g (HGS-150D) approximately 700 g (HGS-700D)
Material of outer parts:	plastic case - polycarbonate stalk with sensor – stainless steel tube (no tube in HGSD) sensor cover - sintered bronze
Outer diameter of connection cables:	minimum 3,5 mm, maximum 8 mm

Terminals and setting of hysteresis

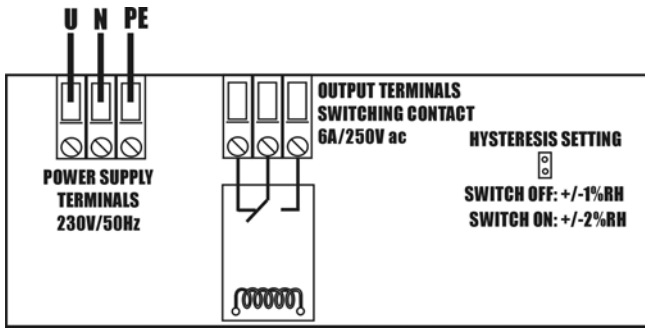

(all types)

Operational range of humidity sensor

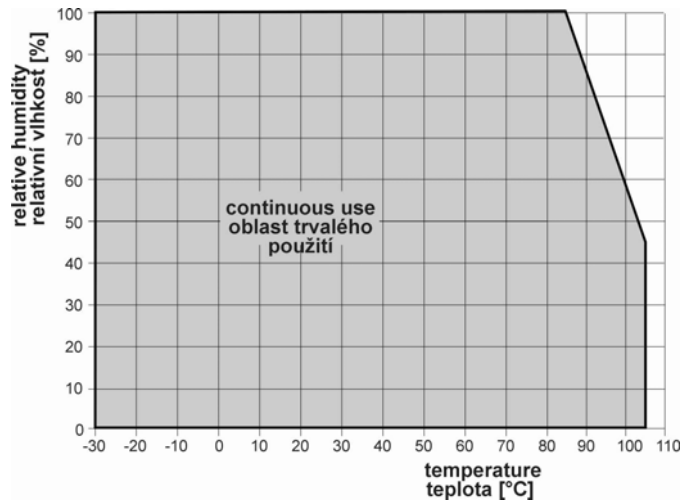

HGSD

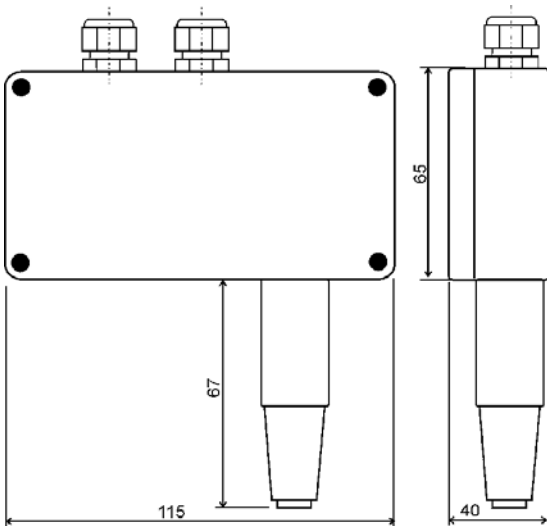

Included is a gland for direct fixing of the bar and duct type regulators to a 29mm diameter hole. Optional accessory is a flat circular flange PP4 or right-angled stainless steel flange PP90 for wall-mounting., see drawings.

HGS.65-150D (-700D)

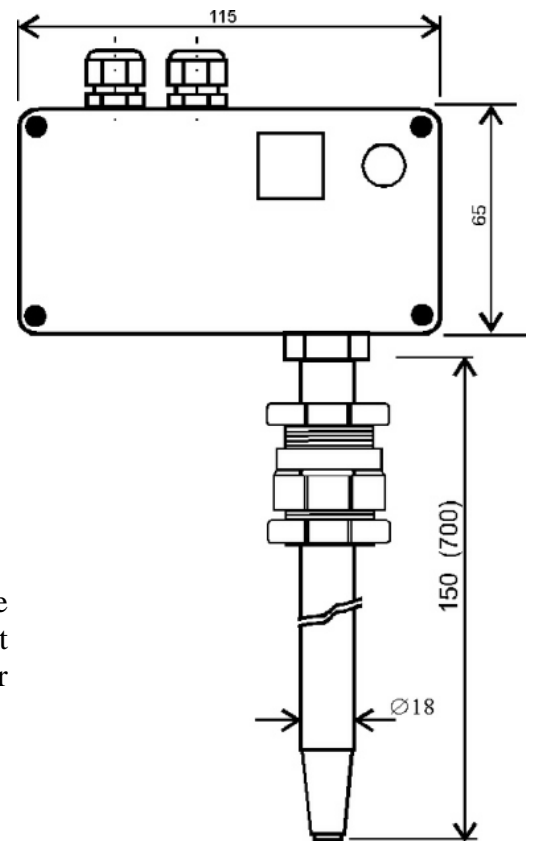

PP4

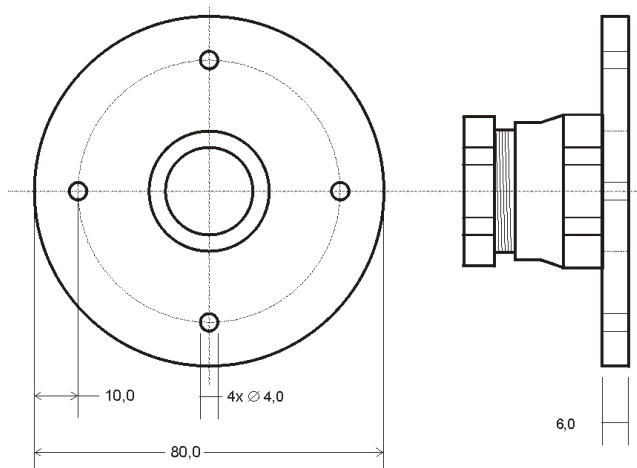

PP90

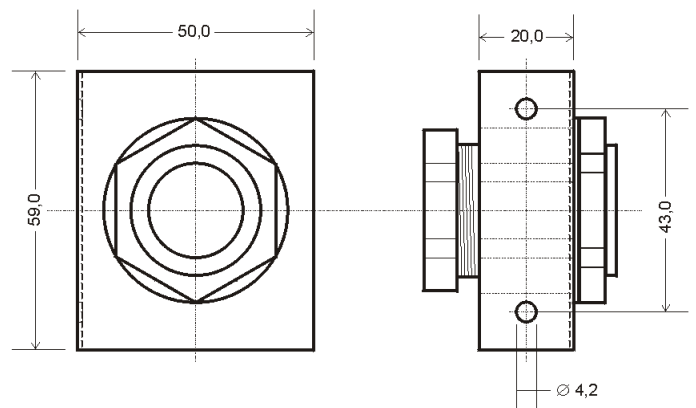

WARNING! All manipulations with removed cover (including hysteresis setting) should be done with regulator DISCONNECTED from power lead 230 V due the safety!

Installation

Regulators are designed for duct or wall mounting. Unscrew four screws at case corners and carefully remove the lid – carefully with the wires! Connect cable to terminals with respecting the signal polarity – see figure. Mounting position for HGSD model for wall mounting is with bronze sensor cover towards down – see figure above. Fix plastic case to the wall by means of two holes at the corners accessible when lid is removed. Mounting position for HGS-150D and HGS-700D regulators is negligible. It is possible to use mounting optional flanges. Locate regulators to the place without direct sun radiation to prevent measurement inaccuracy.

Regulator is designed for permanent connection – easy disconnection by the personnel of its power lead must be ensured by circuit breaker. Lace relay cable through a gland at case the wall and connect to proper terminals accordingly to the figure above. Similarly lace power cable through a gland at case the wall and connect to proper terminals accordingly to the figure above. Tighten glands tightly to prevent cable to be ripped out.

Verification of basic function after installation

Set 0 %RH limit value by the selector. After connection of power voltage 230 V / 50 Hz red LED should light up. This is valid if regulator is located in relative humidity higher than 2 %RH (set limit value + hysteresis should be exceeded).

No maintenance of regulator is required in operation.

Setting of limit value and hysteresis

Set limit humidity by the selector on the instrument from side. Set tens of percents by the left selector and percents by the right selector.

Set hysteresis (dead zone) inside of the regulator (power lead disconnected!) by insertion (± 2 %RH) or removing (± 1 %RH) of the jumper. See figure "Terminals and setting of hysteresis" at previous page.

Putting out of operation

Instrument put out of operation should be liquidated ecologically !