

**Intelligent single channel temperature transducer with Ethernet connection
P8511**

**Intelligent four channel temperature transducer with Ethernet connection
P8541**

**Intelligent temperature meter with Ethernet connection
P8510**

Instruction manual

Introduction

The P8511 transducer is designed to measure temperature through the single external DS 18B20 sensor. The P8541 transducer is designed to measure temperature through the four external DS 18B20 sensors. Sensors are connected through the cinch connector. The P8510 measures temperature through the internal DS 18B20 sensor. The communication with meter is over Ethernet.

General safety rules

The following summary is designed to prevent injury hazards or device damage. Operate the instrument in accordance with this manual to prevent electric trauma.

Service should be performed by a qualified person only.

Precautions against injury or fire

Use a safety ac/dc adapter. Use only an adapter with the power voltage recommended by its manufacturer and which is approved by proper standards. Check that the adapter has undamaged cables and cover.

Connect and disconnect correctly. Do not connect and disconnect a LAN cable or lead-in cables if the device is under electric voltage.

Do not use the instrument without the cover.

Do not use the instrument, if it does not work correctly. If the instrument seems not to work correctly, have it checked by a qualified service person.

Do not use the instrument in an explosive environment.

Content

| | |
|---------------------------------------|----|
| Introduction..... | 2 |
| General safety rules..... | 2 |
| Content..... | 2 |
| General description | 3 |
| Preparation to operation..... | 3 |
| Dimensions..... | 4 |
| Installation..... | 5 |
| Checking operation | 6 |
| Description of device functions | 6 |
| What to do when... .. | 12 |
| Preventive maintenance | 14 |
| Technical specification | 14 |

General description

The P8510, P8511, P8541 devices are designed for measurement of temperature in °C or °F. It is possible to read values from PC through the Ethernet connection. The following formats are supported:

- www pages with user-design possibility
- Modbus protocol
- SNMP protocol
- SOAP

The instrument may send a warning message to several defined points if the measured value gets out of adjusted limits. There are the following possible ways to deliver the warning report:

- to send an e-mail to maximum of three e-mail addresses
- to send a SNMP trap to maximum of three IP addresses
- to display an alarm state on the device www page
- to send a message to syslog server

Alarm limits may be set via Tsensor program, Modbus or telnet. The alarm state may be read via the device www pages, Modbus or the SNMP protocol. If channel isn't wired, it is possible to turn off measured channel.

Preparation to operation

In order to be able to use all the features of the device it is necessary to do some settings by means of a PC. It is necessary to connect a temperature probe before use. A recommended probe is DSTGL40/C.

What is needed to operate instruments

- ac/dc adapter 5V, 250mA
- RJ-45 LAN connection
- free IP address in your network
- for P8511 one temperature probe; for P8541 device max. four temperature probes with DS 18B20 sensor

Contact network administrator to get free IP address

Warning! Safety reception of warning messages (e-mail, trap) depends on actual accessibility of required network services. It is recommended to protect device against the unauthorized access to device settings and connection of cables.

Procedure of instrument connection

- connect the Ethernet connector
- connect the power
- configure the device by means of a PC – in the first run connect probes to device and with the settings program assign probes to desired channels. (not for P8510)

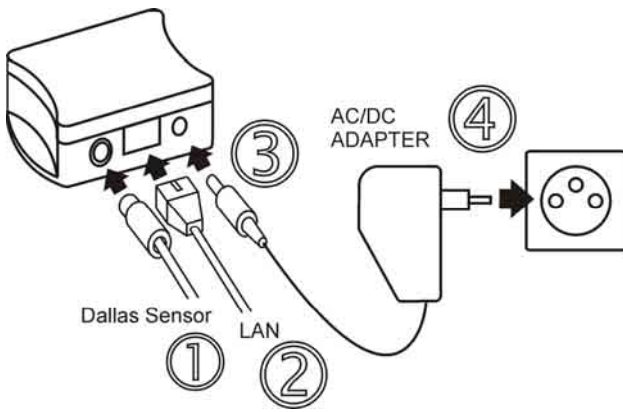

procedure of P8511 connection

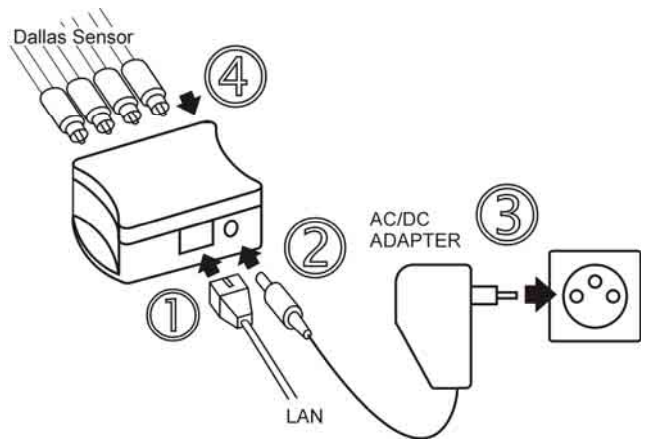

procedure of P8541 connection

Dimensions

P8511

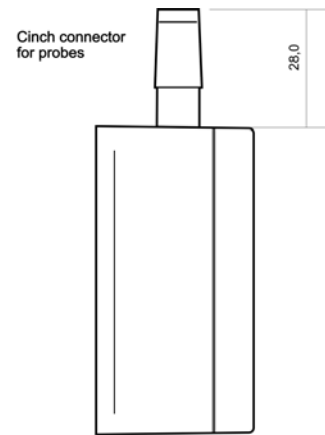
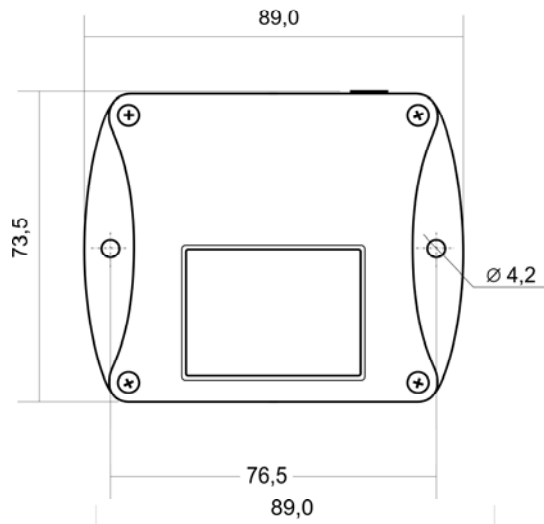

P8541

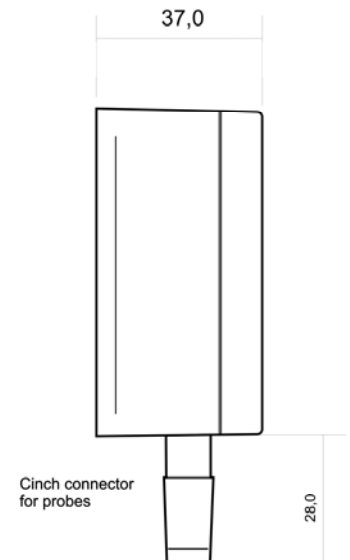
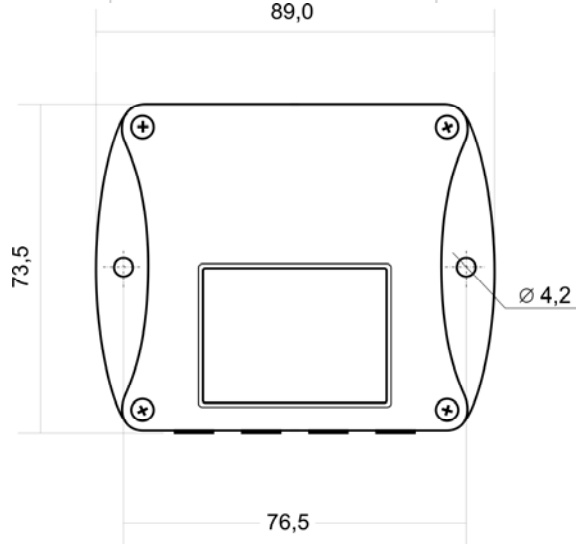

P8510

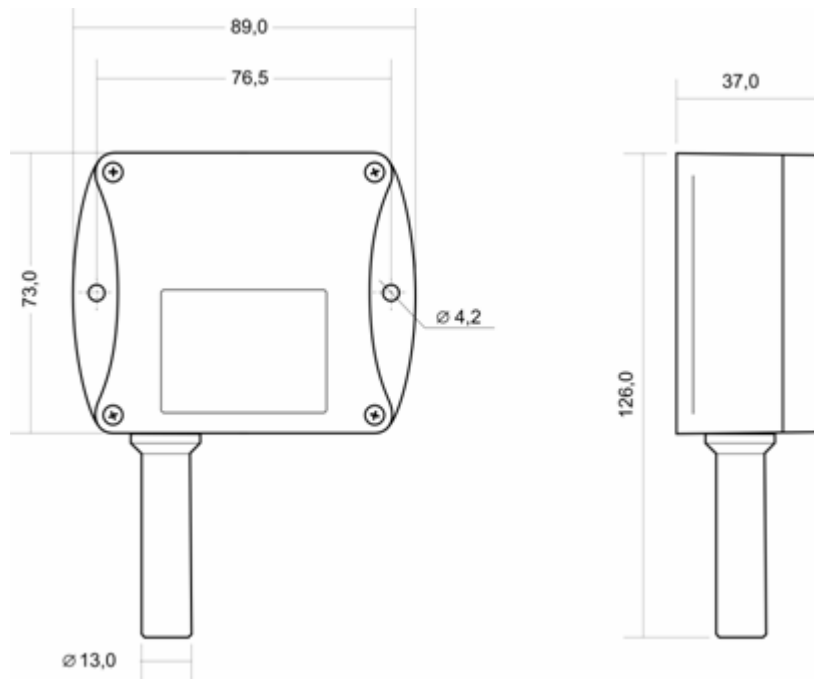

Installation

It is necessary to assign a new suitable IP address to the device at the first connection to it in order to prevent collisions with already existing network IP addresses, and make the address conform with the local habits. If installing several new devices, connect them to the network one after another! If a suitable IP address is not known, contact your network administrator and ask him for the following:

| | | | | |
|------------------|--------|--------|--------|--------|
| IP address: | _____. | _____. | _____. | _____. |
| IP gate address: | _____. | _____. | _____. | _____. |
| Network mask: | _____. | _____. | _____. | _____. |

The IP gate address and the network mask need not be specified if the device will be operated only in a local network. If you set the IP address to one which is already used in the network the device will not work correctly and collisions in the network will appear. It is possible to set the IP address by DHCP server- set the device IP address to 0.0.0.0

The IP address of each device is set by the manufacturer to **192.168.1.213**.

Installation procedure

- run the Tsensor program (default sensor IP address is 192.168.1.213)
- set a new IP address of device
- assign for temperature probes device channels (in P8511 only one channel)
- configure the device in accordance with your requirements (alarm settings, sending of e-mail, traps...)
- store the settings

See more details about use of the Setup in chapter SNTP

The device allows time synchronization with SNTP server. The time synchronization is set to one per day. If the time synchronization failed in next three hours, SNTP trap and e-mail will be sent.

Syslog

Device allow send messages to selected syslog server. Events are described bellow.

| event | text |
|----------------------------------|-----------------------|
| device restart | Device restart |
| test message | Testing message |
| alarm occured | Alarm ... |
| SNTP coonection error | NTP connection error |
| write to device via modbus, SNMP | Settings changed |
| change firmware | Firmware uploaded |
| alarm is down | Clearing ... |
| SOAP server communication error | SOAP connection error |

SOAP

Device allows to send SOAP messages with measured values to user defined remote web server in preset time intervals 10-65535 s. If the web server is not responding in the whole delay interval, device sends trap 1/2 and tries to send next measured data. The file with XML schema is on www.cometsystem.cz/schemas/soapP85xx.xsd.

Setting of device - Setup

Checking operation

After connecting power supply and Ethernet cable the LED on the Ethernet connector is switched ON. Measured values are available through the http protocol, SNMP protocol, Modbus or SOAP (if enabled).

If the measured value exceeds the measuring range of the temperature probe or the temperature probe is not connected correctly Err 1 reading appears (numeric format is 9999). If the channel is disabled, instead current measured value on www pages will be displayed "OFF".

Description of device functions

Information provided by the device can be read by following protocols: http, SNMP, Modbus. Device allows to send SOAP messages to selected web server. To communicate via SNMP, Modbus and SOAP protocols it is necessary to have appropriate software installed on the computer. Such software is not included in the delivery.

The following part describes functions and features of the device.

Alarms

It is possible to set an upper limit, lower limit, hysteresis and time delay (0-65535 s) to each measured channel. Figure shows a temperature curve with some specified upper limit (temp_limit_high) and hysteresis. At point 1 temperature exceeds the limit. From that moment a time delay is counted (time_delay) after which an alarm is set. Because at point 2 the temperature dropped below the limit value (temp_limit_limit) before the time delay expired, alarm was not set.

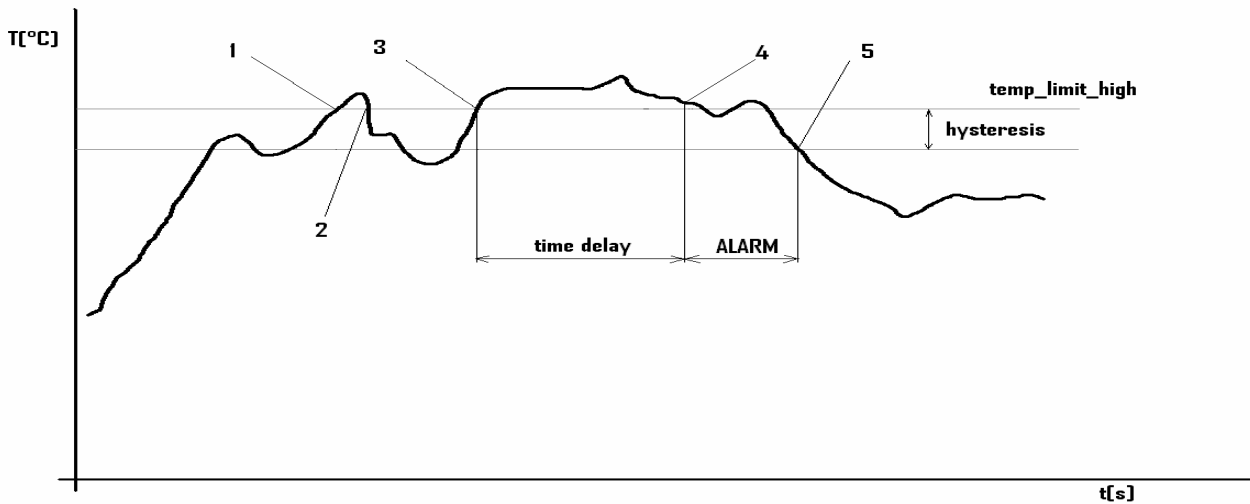

temperature curve

At point 3 the temperature again exceeded the limit, and because it did not drop below the limit value (`temp_limit_high`) before the time delay ended, the alarm was set at point 4. On this moment the alarm e-mails and traps are sent, if they are enabled, and the alarm flag is set (the flag is set when the alarm is active and reset when inactive). The state of the flag can be found on the www pages or via Modbus or the information console. The alarm lasted to point 5, where the temperature dropped below the limit value given by the adjusted hysteresis (`temp_limit_high`– hysteresis).

An alarm report is always sent immediately after an alarm appears. Alarm reports aren't resent. In case of power disconnection or a reset of the device (e.g. by modification of configuration) a new alarm evaluation is performed and new alarm reports are sent again, if any.

It is possible to set the alarm parameters via setting program or telnet. Detailed description of setting can be found in chapters informing about particular services.

Modbus

The device contains support for the Modbus protocol to communicate with control systems. The protocol runs in the RTU mode. The port is set to 502. The Modbus address of the device is always set to 1. Access to port can be disabled in the Setup. Maximal number of client transaction is set to 1.

Supported Modbus commands:

| Command | Code | Description |
|----------------------------|------|---------------------------|
| Read multiple register(s) | 0x03 | Reads 16 bit register(s) |
| Write multiple register(s) | 0x10 | Writes 16 bit register(s) |

Modbus registers of the device¹:

| Address | Address hex | Variable | Type | R/W |
|---------|-------------|-----------------------|--------|-----|
| 40000 | 0x9c40 | channel 1 temperature | Int*10 | R |
| 40001 | 0x9c41 | ch 1 alarm status | Ascii | R |
| 40002 | 0x9c42 | ch 1 upper limit | Int*10 | R/W |
| 40003 | 0x9c43 | ch 1 lower limit | Int*10 | R/W |
| 40004 | 0x9c44 | ch 1 hysteresis | Int*10 | R/W |
| 40005 | 0x9c45 | ch 1 alarm delay | uInt | R/W |
| 40006 | 0x9c46 | ch 2 temperature | Int*10 | R |

¹ Address could be taller by 1 in depend on used Modbus library

| | | | | |
|-------|--------|-------------------|--------|-----|
| 40007 | 0x9c47 | ch 2 alarm status | Ascii | R |
| 40008 | 0x9c48 | ch 2 upper limit | Int*10 | R/W |
| 40009 | 0x9c49 | ch 2 lower limit | Int*10 | R/W |
| 40010 | 0x9c4a | ch 2 hysteresis | Int*10 | R/W |
| 40011 | 0x9c4b | ch 2 alarm delay | uInt | R/W |
| 40012 | 0x9c4c | ch 3 temperature | Int*10 | R |
| 40013 | 0x9c4d | ch 3 alarm status | Ascii | R |
| 40014 | 0x9c4e | ch 3 upper limit | Int*10 | R/W |
| 40015 | 0x9c4f | ch 3 lower limit | Int*10 | R/W |
| 40016 | 0x9c50 | ch 3 hysteresis | Int*10 | R/W |
| 40017 | 0x9c51 | ch 3 alarm delay | uInt | R/W |
| 40018 | 0x9c52 | ch 4 temperature | Int*10 | R |
| 40019 | 0x9c53 | ch 4 alarm status | Ascii | R |
| 40020 | 0x9c54 | ch 4 upper limit | Int*10 | R/W |
| 40021 | 0x9c55 | ch 4 lower limit | Int*10 | R/W |
| 40022 | 0x9c56 | ch 4 hysteresis | Int*10 | R/W |
| 40023 | 0x9c57 | ch 4 alarm delay | uInt | R/W |

Legend:

| | |
|--------|--|
| r | read only register |
| w | register is designed for write |
| Int*10 | register is in format of integer*10 – 16 bits. |
| uInt | register is at range of 0-65535 |
| Ascii | character |

Alarm states can have the following values:

| | |
|----|-------------------------------------|
| no | no alarm |
| lo | value is lower than adjusted limit |
| hi | value is higher than adjusted limit |

SMTP

In case of exceeding adjusted limits of measured values the device can send e-mails to maximum of three addresses. Maximum length of an e-mail address is 55 characters. It is necessary to set your SMTP server address for correct function of e-mail sending. Procedure how to set SMTP is described in chapter Setting.

If limits of several measured values are exceeded a special alarm e-mail is sent for each alarm state. Dummy address `sensor@[device IP address]` is displayed as a sender of the e-mail. It is not possible to reply to this address. In the Subject field of the message the sentence Alarm [Description of the device]² is displayed or Test message [Description of the device] in the case of sending a test e-mail.

The description of the device is preset to the string `P8511 sensor`, or `P8541 sensor` depending on the device model.

SNMP

By means of the SNMP protocol it is possible to find currently measured values and parameters concerning alarms. In case of alarm activation, warning message (a trap) can be sent to specified

² [Description of the device] can be entered in the Setup

addresses. By means of the SNMP protocol it is also possible to display history of last 100 measured values.

For read the device communicates via port 161. Traps are sent via port 162. Sending of traps can be disabled in the Setup.

The following traps sent:

- 0/0 reset of the device
- 1/0 testing trap
- 1/1 communication error with SNTP server
- 1/2 communication error with SOAP server
- 6/3 report on a measured value being outside of the limits or a return of the measured value to the limits

Used mib tables are P85x1.mib and RFC-1213.mib. The path to device is:

iso.org.dod.internet.private.enterprises.comet.products.P85x1

MIB tables are available at www pages <http://www.cometsystem.cz> or on the installation CD (selectable accessories) in the MIB directory. Password for a read operation is set by the manufacturer to PUBLIC and may be changed in the setup.

History

By means of the SNMP protocol it is possible to display history of the last 100 measured values, stored in adjusted time interval. This interval is set in the 10 – 65535 s range. If a value has not been measured yet or an error was detected the value is 9999. The history is erased after each restart of the device.

WWW

The device supports display of measured values, adjusted limits and alarm states on its www pages.

Measured value is in graph displayed by green color, error or not yet measured values are displayed as grey broken line. Upper (lower) alarm value is in graph displayed as red (blue) line. If all values are over upper (lower) limit, the alarm line will be in the bottom (top) graph part displayed.

User can change web design. Details to this action are in separated document, which can be found on www.cometsystem.cz. The factory default web design can be changed in depend on firmware version.

The web address is the same like the device IP.

Example: The device has an IP address 192.168.1.213. Enter <http://192.168.1.213> to the browser address field and confirm it with the Enter key. If your setup enables display of www pages, page will be displayed.

WWW pages have adjustable automatic refresh interval. The manufacturer sets it to 60 seconds. The value can be modified in the setup in a range of 10–65535s.

If the device has www pages display disabled, message “ACCESS DENIED” will be adjusted.

SNTP

The device allows time synchronization with SNTP server. The time synchronization is set to one per day. If the time synchronization failed in next three hours, SNTP trap and e-mail will be sent.

Syslog

Device allow send messages to selected syslog server. Events are described bellow.

| event | text |
|----------------------------------|-----------------------|
| device restart | Device restart |
| test message | Testing message |
| alarm occured | Alarm ... |
| SNTP coonection error | NTP connection error |
| write to device via modbus, SNMP | Settings changed |
| change firmware | Firmware uploaded |
| alarm is down | Clearing ... |
| SOAP server communication error | SOAP connection error |

SOAP

Device allows to send SOAP messages with measured values to user defined remote web server in preset time intervals 10-65535 s. If the web server is not responding in the whole delay interval, device sends trap 1/2 and tries to send next measured data. The file with XML schema is on www.cometsystem.cz/schemas/soapP85xx.xsd.

Setting of device - Setup

The Setup is designed for managing device settings. Setting is performed by means of Tsensor program, or telnet. Setting thru the telnet is described in separated document on <http://www.cometsystem.cz>. Access to the Setup can be protected by a password. The TSensor program you can find on <http://www.cometsystem.cz> or on the installation cd (optional accessory).

Setting of the device:

Run the TSensor program and follow the program instructions. In the next chapter setting options will be described.

Communications setup card

Global settings

Contact your network administrator to get the correct values of the IP address, mask, gateway. Entering incorrect values can cause the device be not found in the network or other complications!

Sensor IP: setting of the IP address of the device.

Get IP from DHCP server: Set the IP address to 0.0.0.0. DHCP server on the network will provide the unit with an IP address, gateway address, and subnet mask when the unit boots up. If you do not change the DHCP name, and you are using an IP of 0.0.0.0, then the DHCP name will default to CXXXXXX (XXXXXX are the last 6 digits of the MAC address shown on the label on the bottom/side of the unit).

For example, if the MAC address is 00-20-4A-12-34-56, then the default DHCP name is C123456. You can change the DHCP name by specifying the last octet of the IP address. When you use this method, the DHCP name will be LTXYY where YY is what you chose for the last octet of the IP address. If the IP address you specify is 0.0.0.12, then the DHCP name will be LTX12. This method will only work with 2 digit numbers (0-99).

Gate IP: setting of the internet gateway. The value need not be entered if the device will operate only in a local network.

Netmask: setting of the network mask of your network.

Example:

| mask | no. of bits |
|------|-------------|
|------|-------------|

| | |
|-----------------|----|
| 255.255.255.252 | 2 |
| 255.255.255.0 | 8 |
| 255.128.0.0 | 23 |

Configuration password: change of the access password for telnet.

Sensor name: The description of the device (it is possible to change it if needed). This description is displayed on WWW pages and in subjects of sent e-mails. Its maximum length is 32 characters.

MTU size: (maximum transmission unit) – maximal packet size. Default setting is 1400, range is from 1400 to 512. If you have some troubles with connection, try reducing the MTU size.

E-mail settings- SMTP configuration

Sending warning e-mail: Enabling of sending warning e-mails after alarm activation.

SMTP IP: setting of an IP address of the SMTP server. Correct setting is required for the device to be able to send e-mails. Contact your network administrator to get the correct address.

Recipient 1-3: e-mail addresses of warning e-mail recipients.

Send test e-mail: In case of confirmation a test e-mail is sent to the specified addresses.

Default e-mail sender: allow change the mail from box.

SNMP- Trap configuration

Traps sending enable: enabling/disabling of sending SNMP traps.

Password for read: setting of the password for access to SNMP protocol.

Password for write: setting of the password for write to SNMP .

Trap IP 1-3: the IP address of recipients of SNMP traps.

Send test trap: Sends a test trap of type 1/0 to the specified IP addresses.

WWW – www settings

Enabled: enables the display of www pages

Refresh: interval for automatic page refresh. Range 10–65535 s.

Modbus - Modbus configuration

Setting of Modbus. The device provides access to measured values by means of the Modbus. The port is set to 502. Changing the Modbus port through the telnet is possible.

Enabled: enables the access to the device

Port: Modbus port.

Probes to channels assign

Button Search probes appear connected probes to table. User can change the channel name. Press left mouse button and move mouse to desired position to assign probe to channel.

SNTP- time settings

SNTP enabled: SNTP synchronization enabled

SNTP IP: IP of SNTP server (from administrator)

UTC+: time shift in minutes

Factory defaults – setting from the manufacturer

This selection sets the Setup items to the following values:

- sets SMTP server address to 0.0.0.0
- erases addresses of e-mail recipients
- disables sending of e-mails
- erases addresses of SNMP traps recipients
- disables sending of traps
- enables display of www pages

- sets refresh time of www pages to 60 seconds
- enables access via Modbus port 502
- sets history logging interval to 60 s
- setting of alarms: upper temperature limit: 80 °C, lower temperature limit -30°C, temperature hysteresis 1 °C, alarm time delay: 30 s
- set device name to P8541-Sensor, P8511-Sensor, or P8511-Sensor depend on sensor type

Communications setup card I

SOAP- sending data to server settings

This function allows to send measured data to remote web server in defined interval

Enabled: SOAP sending enabled

Target SOAP server IP address: remote web server IP address

Target web page: path to web page, where device send the message

Source port: device source port

Destination port: web server port

Sending interval: sending interval to web server

Syslog – sending messages to syslog server

Enabled: sending message to syslog server enabled

SysLog IP address: syslog server IP address

Send syslog message: send test message to syslog server

Configuration card

Alarm settings

Setting of alarms. This submenu contains:

- setting of upper temperature limit
- setting of lower temperature limit
- setting of temperature hysteresis
- setting of temperature time delay

Save changes

Saves modifications to the memory and resets the device.

What to do when...

I forgot the IP address of the device

IP address is set to the value 192.168.1.213 by the manufacturer. If you changed it and forgot the new IP address, run the TSensor program and press the “Find...” button. In a new window all sensors will be show.

It is not possible to connect to the device from a LAN

In the “Find device” window is only IP and MAC address displayed

The next information is displayed as N/A. This problem will be occurred, when the device IP is set to another LAN.

In TSensor program choose Find device/Change IP address. Follow the program instruction.

The sensor IP address in Find device window is not displayed

In TSensor program select Find device/Help my device Wasn't found!. Follow the program instruction.

Finding the MAC address

The MAC address is a unique address of a device which is necessary to be known e.g. in case when there are several devices connected to the network. MAC address is on device label.

It is not possible to find meter after manual MAC enter

In TSensor program select Find device/Help my device Wasn't found. In this select "Set IP to ARP only". To "Device MAC address" enter the meter MAC address (e.g. 00-20-4A-84-F0-80) and press the "Set IP" button.

Open telnet to the IP address you assigned to the device MAC address by running a telnet command `telnet [IP_address_assigned_to_MAC_address] 9999` and confirm with the Enter key. Choose 0- Global Settings, set the meters IP address, clear the gate IP, no. of net mask set to 0. Pres the Enter key, until you are not back into a menu. Press 9 Save and Exit. The connection will be closed. Now you can connect to meter by the TSensor program.

There is an Error 1

- check if a temperature probe is connected or if the temperature probe is not at a temperature outside the measuring range
- check the integrity of the probe cable

Forgotten password to the setup

- disconnect the power
- unscrew upper lid of the device case
- press the button inside the device and connect the power at the same time. Keep the button pressed
- keep the button pressed for 10 s - then the password will be erased
- close the device

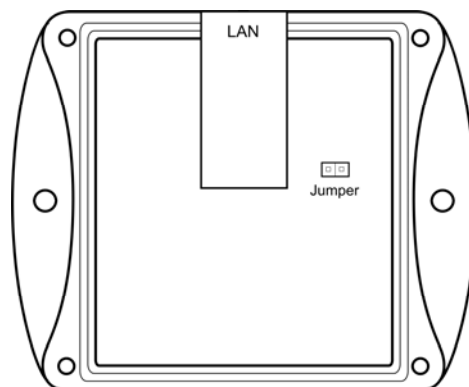

jumper placing

Preventive maintenance

Do not subject the device to mechanical stress.
Recommended calibration interval is 2 years.

Technical specification

Technical parameters:

Power voltage: 5 V DC, coaxial connector, diameter 5 x 2.1 mm, positive pole in middle

Usage: approximately 1 W

Measuring interval: 2 s

Communication with computer: Ethernet connection (RJ-45 connector)

Protection: IP30 - case with electronics

EMC: device complies with EN 61326-1:

Devices are conformed to EN 50081-1 and EN 50082-1 in the range:

| | | |
|------------|--------------|---|
| Radiation: | EN 55022 | class B |
| Immunity: | EN 61000-4-2 | levels 4/8 kV, class A |
| | EN 61000-4-3 | intensity of electromagnetic field 3 V/m, class A |
| | EN 61000-4-4 | levels 1/0.5 kV, class A |
| | EN 61000-4-6 | intensity of electromagnetic field 3 V/m, class A |

Temperature measuring range: -30 to +80 °C

Temperature resolution: 0,1 °C

P8511,P8541

Recommended probe: DSTGL40/C, maximum cable length is 10 m.

Cinch connection: pin DQ DS18B20 to cinch center, VDO and GND connect to connector case.

P8510

Accuracy: ±0,8 °C

Operating conditions

Operating temperature and humidity range: electronics: -30 to +80 °C, 0 to 100 % RH (not condensing)

Outer characteristics in accordance with EN 33-2000-3: Normal environment with the specifications: AE1, AN1, AR1, BE1

Working position: arbitrary

Installation of the instrument: by means of two holes at the bottom part

Limits on conditions (the device without a probe): temperature -40 to +80 °C, humidity 0 to 100 %RH not condensing

Mechanical dimensions of the case (W x H x D): **P8511, P8541** 89 x 74 x 36 mm
P8510 89x126x36 mm

Weight: approximately 240 g

Material of the case: ABS

Liquidation: Device itself (after its life) is necessary to liquidate ecologically!

Technical support and service

Technical support is provided by distributor of this device. Contact is in included warranty certificate.